

VICTORIA

HIGH-WALL DUCTLESS AIR CONDITIONING & HEATING SYSTEM

INSTALLATION MANUAL

Models:

CH09VCT115VI/CH09VCT115VO

CH12VCT115VI/CH12VCT115VO

CH09VCT230VI/CH09VCT230VO

CH12VCT230VI/CH12VCT230VO

CH18VCT230VI/CH18VCT230VO

CH24VCT230VI/CH24VCT230VO

INVERTER



CH09VCT115VI/CH09VCT115VO (115V)

System Includes: CH09VCT115VI, CH09VCT115VO

CH12VCT115VI/CH12VCT115VO (115V)

System Includes: CH12VCT115VI, CH12VCT115VO

CH09VCT230VI/CH09VCT230VO (230V)

System Includes: CH09VCT230VI, CH09VCT230VO

CH12VCT230VI/CH12VCT230VO (230V)

System Includes: CH12VCT230VI, CH12VCT230VO

CH18VCT230VI/CH18VCT230VO (230V)

System Includes: CH18VCT230VI, CH18VCT230VO

CH24VCT230VI/CH24VCT230VO (230V)

System Includes: CH24VCT230VI, CH24VCT230VO

Explanation of Symbols



DANGER

Indicates a hazardous situation that, if not avoided, will result in death or serious injury.



WARNING

Indicates a hazardous situation that, if not avoided, could result in death or serious injury.



CAUTION

Indicates a hazardous situation that, if not avoided, may result in minor or moderate injury.

NOTICE

Indicates important but not hazard-related information, used to indicate risk of property damage.



Indicates a hazard that would be assigned a signal word **WARNING** or **CAUTION**.

Content

Installation Notice

Precautions	1
System Requirements Piping Requirements	6
Installation dimension diagram	7
Tools for installation	8
Selection of installation location	8
Requirements for electric connection	9

Installation

Installation of indoor unit.	10
Installation of outdoor unit.	15
Vacuum pumping	19
Leakage detection.	19
Check after installation.	20

Test and operation

Test operation	20
--------------------------	----

Attachment

Configuration of connection pipe	21
Pipe expanding method.	23
Start-Up and troubleshooting.	24



WARNING

Operation and Maintenance

- This appliance is not intended for use by persons (including children) with reduced physical, sensory or mental capabilities, or lack of experience and knowledge, unless they have been given supervision or instruction concerning use of the appliance by a person responsible for their safety. Children should be supervised to ensure that they do not play with the appliance.
- Children shall not play with the appliance.
- Cleaning and user maintenance shall not be made by children without supervision.
- Do not connect air conditioner to multi-purpose socket. Otherwise, it may cause fire hazard.
- Do disconnect power supply when cleaning air conditioner. Otherwise, it may cause electric shock.
- If the supply cord is damaged, it must be replaced by the manufacturer, its service agent or similarly qualified persons in order to avoid a hazard.
- Do not wash the air conditioner with water to avoid electric shock.
- Do not spray water on indoor unit. It may cause electric shock or malfunction.
- After removing the filter, do not touch fins to avoid injury.
- Do not use fire or hair dryer to dry the filter to avoid deformation or fire hazard.

Precautions



WARNING

- Maintenance must be performed by qualified professionals. Otherwise, it may cause personal injury or damage.
- Do not repair air conditioner by yourself. It may cause electric shock or damage. Please contact dealer when you need to repair air conditioner.
- Do not extend fingers or objects into air inlet or air outlet. It may cause personal injury or damage.
- Do not block air outlet or air inlet. It may cause malfunction.
- Do not spill water on the remote controller, otherwise the remote controller may be broken.
- When below phenomenon occurs, please turn off air conditioner and disconnect power immediately, and then contact the dealer or qualified professionals for service.
 - Power cord is overheating or damaged.
 - There's abnormal sound during operation.
 - Circuit break trips off frequently.
 - Air conditioner gives off burning smell.
 - Indoor unit is leaking.
- If the air conditioner operates under abnormal conditions, it may cause malfunction, electric shock or fire hazard.
- When turning on or turning off the unit by emergency operation switch, please press this switch with an insulating object other than metal.
- Do not step on top panel of outdoor unit, or put heavy objects. It may cause damage or personal injury.

Precautions



WARNING

Attachment

- Installation must be performed by qualified professionals. Otherwise, it may cause personal injury or damage.
- Must follow the electric safety regulations when installing the unit.
- According to the local safety regulations, use qualified power supply circuit and circuit break.
- Do install the circuit break. If not, it may cause malfunction.
- An all-pole disconnection switch having a contact separation of at least 1/8in (3mm) in all poles should be connected in fixed wiring.
- Including an circuit break with suitable capacity, please note the following table. Air switch should be included magnet buckle and heating buckle function, it can protect the circuit-short and overload.
- Air Conditioner should be properly grounded. Incorrect grounding may cause electric shock.
- Don't use unqualified power cord.
- Make sure the power supply matches with the requirement of air conditioner. Unstable power supply or incorrect wiring or malfunction. Please install proper power supply cables before using the air conditioner.
- Properly connect the live wire, neutral wire and grounding wire of power socket.
- Be sure to cut off the power supply before proceeding any work related to electricity and safety.

Precautions



WARNING

- Do not put through the power before finishing installation.
- If the supply cord is damaged, it must be replaced by the manufacturer, its service agent or similarly qualified persons in order to avoid a hazard.
- The temperature of refrigerant circuit will be high, please keep the interconnection cable away from the copper tube.
- The appliance shall be installed in accordance with national wiring regulations.
- Installation must be performed in accordance with the requirement of National Electrical Codes (NEC) and local electrical codes by authorized personnel only.
- The air conditioner is the first class electric appliance. It must be properly grounding with specialized grounding device by a professional. Please make sure it is always grounded effectively, otherwise it may cause electric shock.
- The yellow-green wire in air conditioner is grounding wire, which can't be used for other purposes.
- The grounding resistance should comply with national electric safety regulations.
- The appliance must be positioned so that the plug is accessible.
- All wires of indoor unit and outdoor unit should be connected by a professional.
- If the length of power connection wire is insufficient, please contact the supplier for a new one. Avoid extending the wire by yourself.

Precautions



WARNING

- For the air conditioner with plug, the plug should be reachable after finishing installation.
- For the air conditioner without plug, an circuit break must be installed in the line.
- If you need to relocate the air conditioner to another place, only the qualified person can perform the work. Otherwise, it may cause personal injury or damage.
- Select a location which is out of reach for children and far away from animals or plants. If it is unavoidable, please add the fence for safety purpose.
- The indoor unit should be installed close to the wall.

Working temperature range

	Indoor side DB/WB(°C/°F)	Outdoor side DB/WB(°C/°F)
Maximum cooling	26.7/19.4(80/66.9)	46.1/23.9(115/75)
Maximum heating	26.7/-(80/-)	23.9/18.3(75/64.9)

NOTICE:

- The operating temperature range (outdoor temperature) for cooling only unit is -0.4°F(-18°C)~115°F(46.1°C); for heat pump unit is -4°F(-20°C)~115°F(46.1°C).

System Requirements

Piping Requirements

PIPE SIZE in (mm)

Unit Size (BtuH)	Voltage	Liquid Line	Suction/Gas Line
9,000	115v - 1ph 60hz	1/4 (6)	3/8 (9.5)
12,000	115v - 1ph 60hz	1/4 (6)	1/2 (12)
9,000	208/230v - 1ph 60hz	1/4 (6)	3/8 (9.5)
12,000	208/230v - 1ph 60hz	1/4 (6)	1/2 (12)
18,000	208/230v - 1ph 60hz	1/4 (6)	5/8 (15.8)
24,000	208/230v - 1ph 60hz	1/4 (6)	5/8 (15.8)

REFRIGERANT LINE LENGTHS ft (m)

Unit Size (BtuH)	Voltage	Min Line Length	Max Line Length	Max Elevation (ID over OD)
9,000	115v - 1ph 60hz	10 (3)	66 (20)	33 (10)
12,000	115v - 1ph 60hz	10 (3)	66 (20)	33 (10)
9,000	208/230v - 1ph 60hz	10 (3)	50 (15)	33 (10)
12,000	208/230v - 1ph 60hz	10 (3)	50 (15)	33 (10)
18,000	208/230v - 1ph 60hz	10 (3)	82 (25)	33 (10)
24,000	208/230v - 1ph 60hz	10 (3)	82 (25)	33 (10)

Notes: Insulate both refrigerant lines, separately.

REFRIGERANT CHARGE

Unit Size (BtuH)	Voltage	Refrigerant Type	Factory System Charge oz (kg)*	Additional Charge oz/ft (g/m)
9,000	115v - 1ph 60hz	R410A	35.3 (1.0)	0.2 (20)
12,000	115v - 1ph 60hz	R410A	35.3 (1.0)	0.2 (20)
9,000	208/230v - 1ph 60hz	R410A	26.1 (0.74)	0.2 (20)
12,000	208/230v - 1ph 60hz	R410A	35.3 (1.0)	0.2 (20)
18,000	208/230v - 1ph 60hz	R410A	45.9 (1.3)	0.2 (20)
24,000	208/230v - 1ph 60hz	R410A	54.7 (1.6)	0.2 (20)

*Precharge amount for up to 25-ft of refrigerant pipe.

ELECTRICAL REQUIREMENTS

Unit Size (BtuH)	Voltage	Min Circuit Amps (MCA)	Max Overcurrent Protection (MOP)	Main Power Wire Size (AWG)**
9,000	115v - 1ph 60hz	13	20	12
12,000	115v - 1ph 60hz	15	25	12
9,000	208/230v - 1ph 60hz	10	15	16
12,000	208/230v - 1ph 60hz	10	15	16
18,000	208/230v - 1ph 60hz	16	25	14
24,000	208/230v - 1ph 60hz	20	30	12

**Main power wire from electrical panel to outdoor unit.

- Notes:
- 1) System must be on a single dedicated circuit.
 - 2) Main power is supplied to the outdoor unit.
 - 3) Use table above to size over current protection.
 - 4) Follow all local building codes and NEC (National Electrical Code) regulations. Interconnecting Cable:

Recommended cable - 16/4 AWG stranded bare copper conductors THHN 600V unshielded wire

Note: Use shield cable if installation is in close proximity of RF and EMI transmitting devices.

Condensate Drain Size: 5/8-in OD 7/16-in ID Note: Insulate condensate drain hose to prevent sweating and possible water damage.

Installation dimension diagram

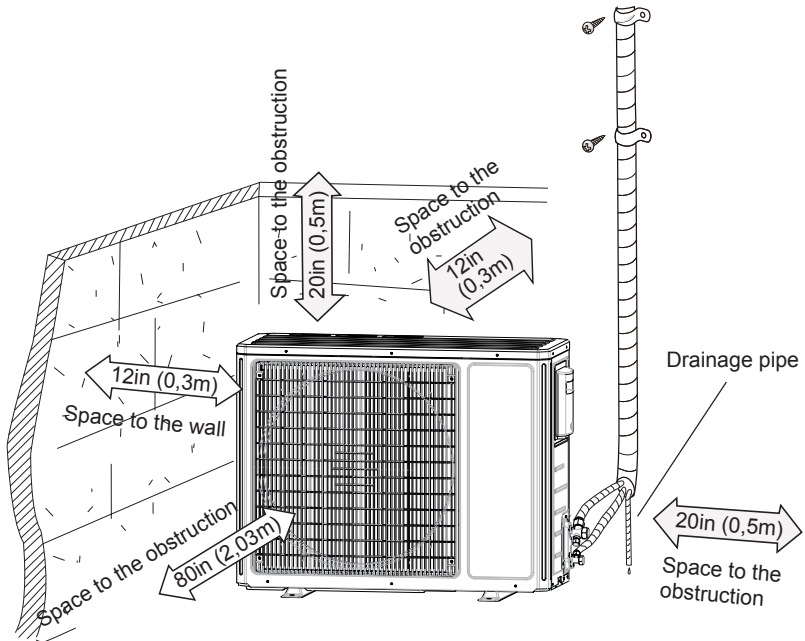
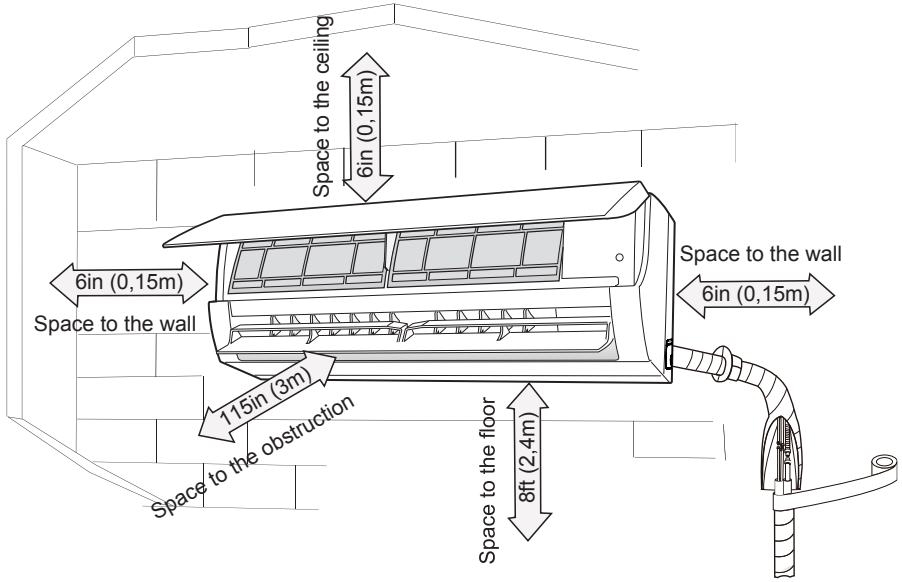

Tools for installation

1 Level meter	2 Screw driver	3 Impact drill
4 Drill head	5 Pipe expander	6 Torque wrench
7 Open-end wrench	8 Pipe cutter	9 Leakage detector
10 Vacuum pump	11 Pressure meter	12 Universal meter
13 Inner hexagon spanner		14 Measuring tape

Note:

- Please contact the local agent for installation.
- Don't use unqualified power cord.

Selection of installation location

Basic requirement

Installing the unit in the following places may cause malfunction. If it is unavoidable, please consult the local dealer:

1. The place with strong heat sources, vapors, flammable or explosive gas, or volatile objects spread in the air.
2. The place with high-frequency devices (such as welding machine, medical equipment).
3. The place near coast area.
4. The place with oil or fumes in the air.
5. The place with sulfured gas.
6. Other places with special circumstances.
7. Do not use the unit in the immediate surroundings of a laundry, bath, shower or a swimming pool.

Indoor unit

1. There should be no obstruction near air inlet and air outlet.
2. Select a location where the condensation water can be dispersed easily and won't affect other people.
3. Select a location which is convenient to connect the outdoor unit and near the power socket.
4. Select a location which is out of reach for children.
5. The location should be able to withstand the weight of indoor unit and won't increase noise and vibration.
6. The appliance must be installed 8,2ft (2.5m) above floor.
7. Don't install the indoor unit right above the electric appliance.
8. Please try your best to keep away from fluorescent lamp.

Outdoor unit

1. Select a location where the noise and outflow air emitted by the outdoor unit will not affect neighborhood.
2. The location should be well ventilated and dry, in which the outdoor unit won't be exposed directly to sunlight or strong wind.
3. The location should be able to withstand the weight of outdoor unit.
4. Make sure that the installation follows the requirement of installation dimension diagram.
5. Select a location which is out of reach for children and far away from animals or plants. If it is unavoidable, please add the fence for safety purpose.

Requirements for electric connection

Safety precaution

1. Must follow the electric safety regulations when installing the unit.
2. According to the local safety regulations, use qualified power supply circuit and circuit break.
3. Make sure the power supply matches with the requirement of air conditioner. Unstable power supply or incorrect wiring or malfunction. Please install proper power supply cables before using the air conditioner.
4. Properly connect the live wire, neutral wire and grounding wire of power socket.
5. Be sure to cut off the power supply before proceeding any work related to electricity and safety.
6. Do not put through the power before finishing installation.
7. If the supply cord is damaged, it must be replaced by the manufacturer, its service agent or similarly qualified persons in order to avoid a hazard.
8. The temperature of refrigerant circuit will be high, please keep the interconnection cable away from the copper tube.
9. The appliance shall be installed in accordance with national wiring regulations.
10. Installation must be performed in accordance with the requirement of NEC by authorized personnel only

Grounding requirement

1. The air conditioners is the first class electric appliance. It must be properly grounding with specialized grounding device by a professional. Please make sure it is always grounded effectively, otherwise it may cause electric shock.
2. The yellow-green wire in air conditioner is grounding wire, which can't be used for other purposes.
3. The grounding resistance should comply with national electric safety regulations.
4. The appliance must be positioned so that the plug is accessible.
5. An all-pole disconnection switch having a contact separation of at least 1/8in (3mm) in all poles should be connected in fixed wiring.
6. Including an circuit break with suitable capacity, please note the following table. Air switch should be included magnet buckle and heating buckle function, it can protect the circuit-short and overload. (Caution: please do not use the fuse only for protect the circuit)

Air-conditioner	Circuit break capacity
09、12K	15A
09K(115V)	20A
12K(115V)	25A
18K	25A
24K	30A

Installation of indoor unit

Step one: choosing installation location

Recommend the installation location to the client and then confirm it with the client.

Step two: install wall-mounting frame

1. Hang the wall-mounting frame on the wall; adjust it in horizontal position with the level meter and then point out the screw fixing holes on the wall.
 2. Drill the screw fixing holes on the wall with impact drill (the specification of drill head should be the same as the plastic expansion particle) and then fill the plastic expansion particles in the holes.
 3. Fix the wall-mounting frame on the wall with tapping screws (ST4.2X25TA) and then check if the frame is firmly installed by pulling the frame. If the plastic expansion particle is loose, please drill another fixing hole nearby.
-

Step three: open piping hole

1. Choose the position of piping hole according to the direction of outlet pipe. The position of piping hole should be a little lower than the wall-mounted frame, shown as below.

09、12K:

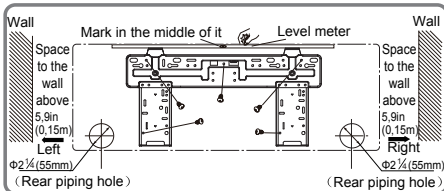

18K:

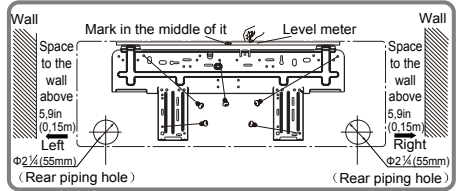

24K:

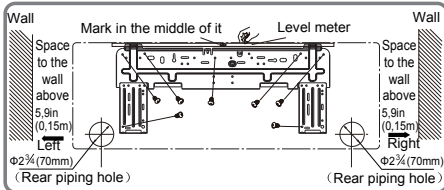

2. Open a piping hole with the diameter of $\Phi 2 \frac{1}{4} / 2 \frac{3}{4}$ on the selected outlet pipe position. In order to drain smoothly, slant the piping hole on the wall slightly downward to the outdoor side with the gradient of 5-10°.

Installation of indoor unit

Note:

- Pay attention to dust prevention and take relevant safety measures when opening the hole.
- The plastic expansion particles are not provided and should be bought locally.

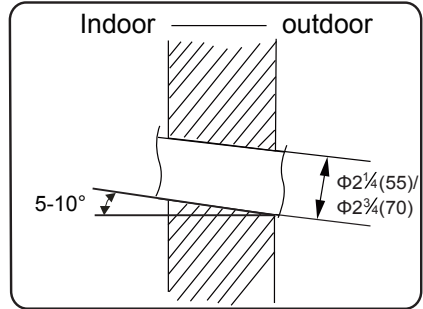

Step four: outlet pipe

1. The pipe can be led out in the direction of right, rear right, left or rear left.

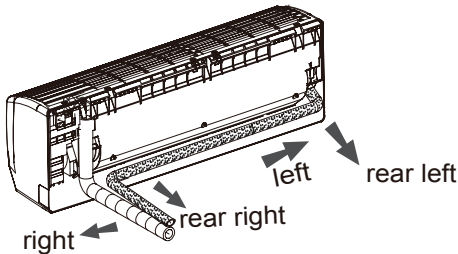

2. When select leading out the pipe from left or right, please cut off the corresponding hole on the bottom case.

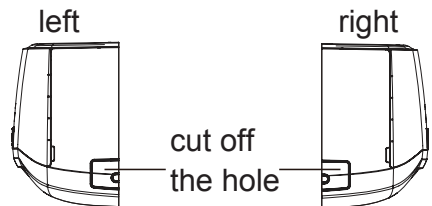

Step five: connect the pipe of indoor unit

1. Aim the pipe joint at the corresponding bellmouth.
2. Pretightening the union nut with hand.

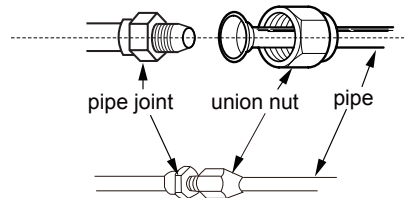

3. Adjust the torque force by referring to the following sheet. Place the open-end wrench on the pipe joint and place the torque wrench on the union nut. Tighten the union nut with torque wrench.

Installation of indoor unit

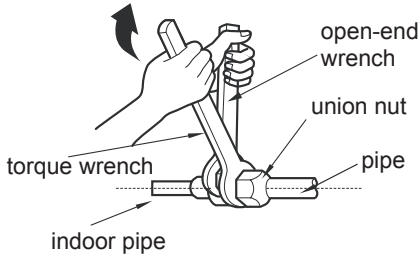

Hex nut diameter	Tightening torque (N·m)
$\Phi 1/4$	15~20
$\Phi 3/8$	30~40
$\Phi 1/2$	45~55
$\Phi 5/8$	60~65
$\Phi 3/4$	70~75

4. Wrap the indoor pipe and joint of connection pipe with insulating pipe, and then wrap it with tape.

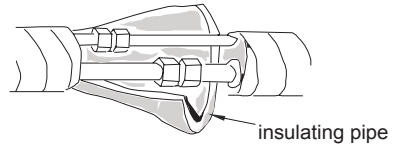

Step six: install drain hose

1. Connect the drain hose to the outlet pipe of indoor unit.

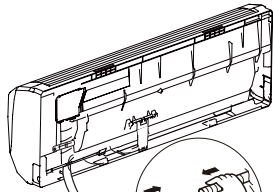

2. Bind the joint with tape.

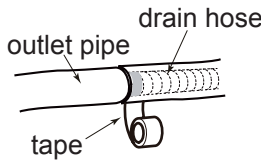

Note:

- Add insulating pipe in the indoor drain hose in order to prevent condensation.
- The plastic expansion particles are not provided.

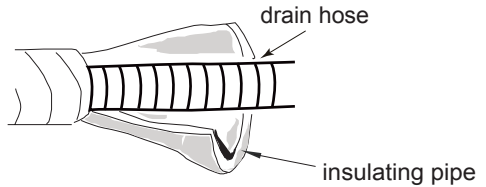

Step seven: connect wire of indoor unit

1. Open the panel, remove the screw on the wiring cover and then take down the cover.

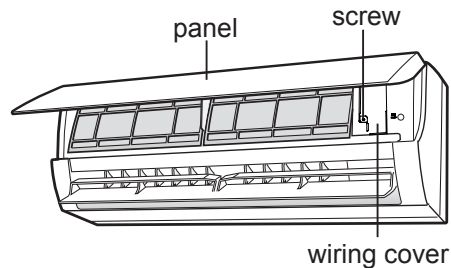

Installation of indoor unit

2. Make the power connection wire go through the cable-cross hole at the back of indoor unit and then pull it out from the front side.

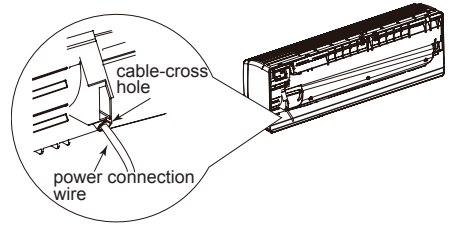

3. Remove the wire clip; connect the power connection wire to the wiring terminal according to the color; tighten the screw and then fix the power connection wire with wire clip.

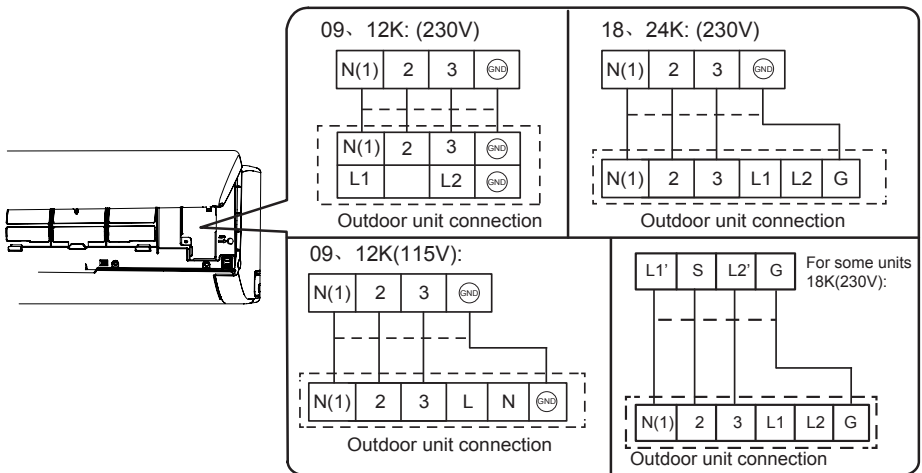

4. Put wiring cover back and then tighten the screw.
5. Close the panel.

Note:

- All wires of indoor unit and outdoor unit should be connected by a professional. Connect main power wires and conduit to unit disconnect switch box per manufacturer's instructions, National Electrical Code (NEC) and local electrical codes.
- If the length of power connection wire is insufficient, please contact the supplier for a new one. Avoid extending the wire by yourself.
- For the air conditioner with plug, the plug should be reachable after finishing installation.
- For the air conditioner without plug, an circuit break must be installed in the line. The circuit break should be all-pole parting and the contact parting distance should be more than 1/8in.

Installation of indoor unit

Step eight: bind up pipe

1. Bind up the connection pipe, power cord and drain hose with the band.

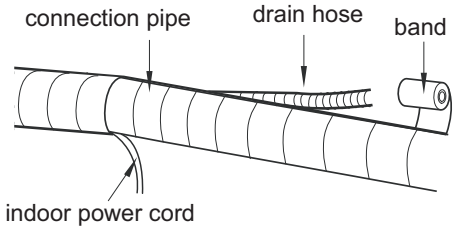
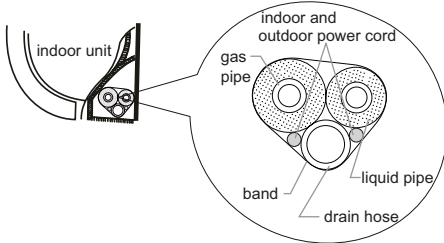

2. Reserve a certain length of drain hose and power cord for installation when binding them. When binding to a certain degree, separate the indoor power and then separate the drain hose.

3. Bind them evenly.
4. The liquid pipe and gas pipe should be bound separately at the end.

Note:

- The power cord and control wire can't be crossed or winding.
- The drain hose should be bound at the bottom.

Step nine: hang the indoor unit

1. Put the bound pipes in the wall pipe and then make them pass through the wall hole.
2. Hang the indoor unit on the wall-mounting frame.
3. Stuff the gap between pipes and wall hole with sealing gum.
4. Fix the wall pipe.
5. Check if the indoor unit is installed firmly and closed to the wall.

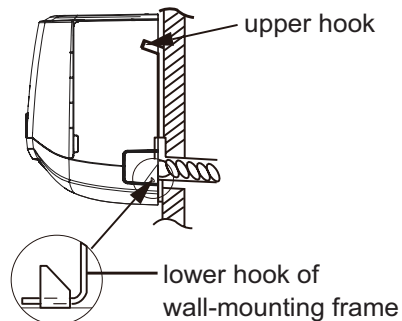
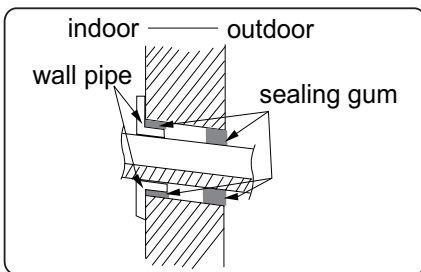

Note:

- Do not bend the drain hose too excessively in order to prevent blocking.

Installation of outdoor unit

Step one: fix the support of outdoor unit

(select it according to the actual installation situation)

1. Select installation location according to the house structure.
2. Fix the support of outdoor unit on the selected location with expansion screws.

Note:

- Take sufficient protective measures when installing the outdoor unit.
- Make sure the support can withstand at least four times of the unit weight.
- The outdoor unit should be installed at least 3cm above the floor in order to install drain joint.
- For the unit with cooling capacity of 2300W ~5000W, 6 expansion screws are needed;
- for the unit with cooling capacity of 6000W ~8000W, 8 expansion screws are needed;
- for the unit with cooling capacity of 10000W ~16000W, 10 expansion screws are needed.

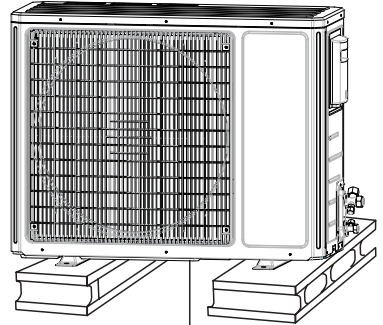

at least 1 1/8 in above the floor

Step two: install drain joint (Only for cooling and heating unit)

1. Connect the outdoor drain joint into the hole on the chassis, as shown in the picture below.
2. Connect the drain hose into the drain vent.

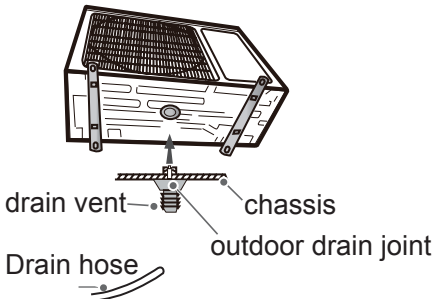

Step three: fix outdoor unit

1. Place the outdoor unit on the support.
2. Fix the foot holes of outdoor unit with bolts.

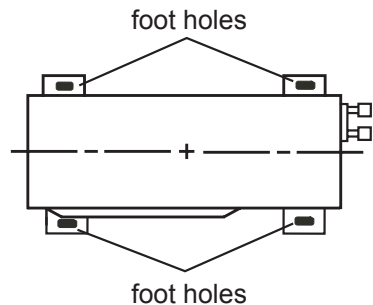

Installation of outdoor unit

Step four: connect indoor and outdoor pipes

1. Remove the screw on the right handle of outdoor unit and then remove the handle.

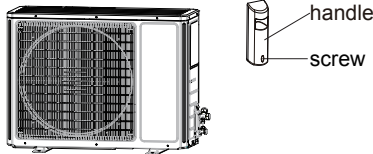

2. Remove the screw cap of valve and aim the pipe joint at the bellmouth of pipe.

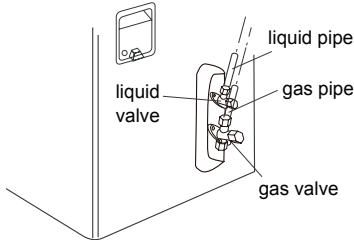

3. Pretightening the union nut with hand.

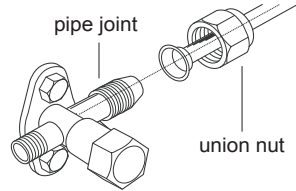

4. Tighten the union nut with torque wrench by referring to the sheet below.

Hex nut diameter	Tightening torque (N·m)
$\Phi\frac{1}{4}$	15~20
30~40 $\Phi\frac{3}{8}$	
45~55 $\Phi\frac{1}{2}$	
$\Phi\frac{5}{8}$	60~65
$\Phi\frac{3}{4}$	70~75

Step five: connect outdoor electric wire

1. Remove the wire clip; connect the power connection wire and signal control wire (only for cooling and heating unit) to the wiring terminal according to the color; fix them with screws.

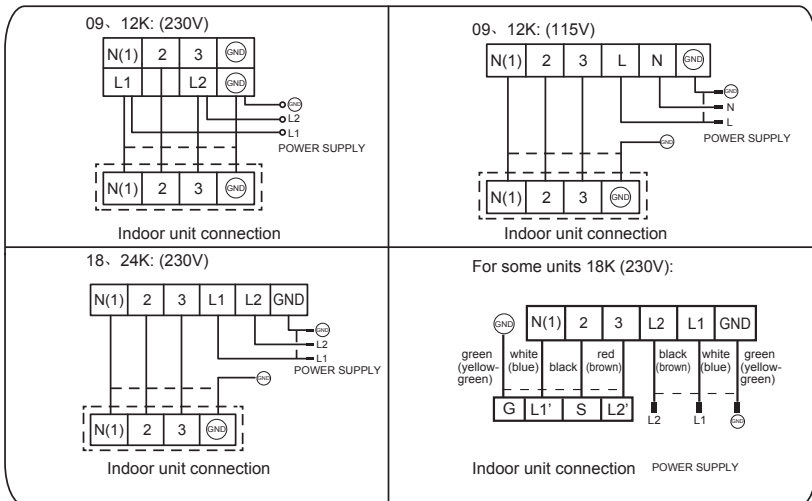

Installation of outdoor unit

2. Fix the power connection wire and signal control wire with wire clip (only for cooling and heating unit).

Note:

- After tighten the screw, pull the power cord slightly to check if it is firm.
- Never cut the power connection wire to prolong or shorten the distance.

Step six: neaten the pipes

1. The pipes should be placed along the wall, bent reasonably and hidden possibly. Min. semidiameter of bending the pipe is 4in(10cm).
2. If the outdoor unit is higher than the wall hole, you must set a U-shaped curve in the pipe before pipe goes into the room, in order to prevent rain from getting into the room.

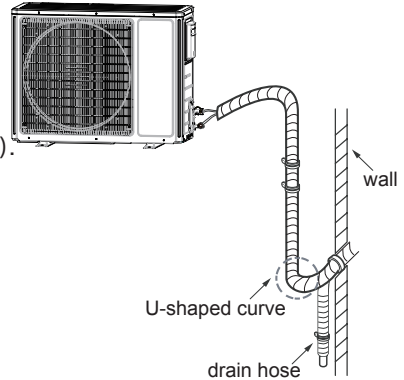

Outdoor Condensate Drainage (only for Heat pump unit)

During heating operation, the condensate and defrosting water should be drained out reliably through the drain hose. Install the outdoor drain connector in a $\Phi 1$ hole or $\Phi 1\frac{5}{8}$ hole on the base plate and attach the drain hose to the connector so that the waste water formed in the outdoor unit can be drained out. The hole diameter $\Phi 1$ or $\Phi 1\frac{5}{8}$ must be plugged.

Whether to plug other holes will be determined by the dealers to actual conditions.

09. 12K UNIT:

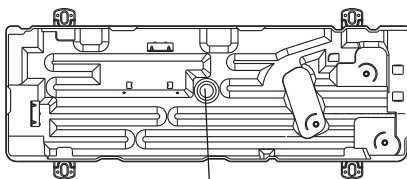

Drain-water hole
Bottom frame

18K UNIT:

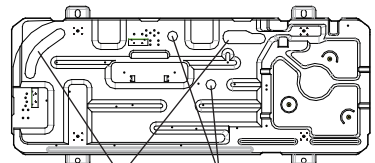

drain hole Drain-water hole
Bottom frame

24K UNIT:

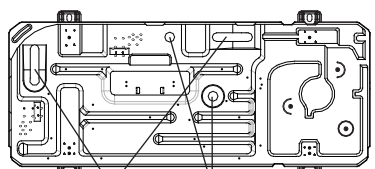

drain hole Drain-water hole
Bottom frame

Installation of outdoor unit

The 18K QD、24K QE UNIT drainage hole consists of two $\Phi 1''$ and two kidney holes (see the fig.1). The drain plug consists of one $\Phi 1''$ and two kidney plugs.
(The figures in this manual may be different with the material objects, please refer to the material objects for reference)

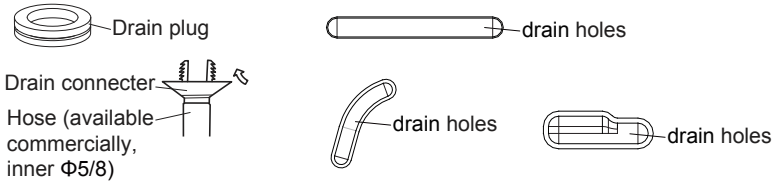
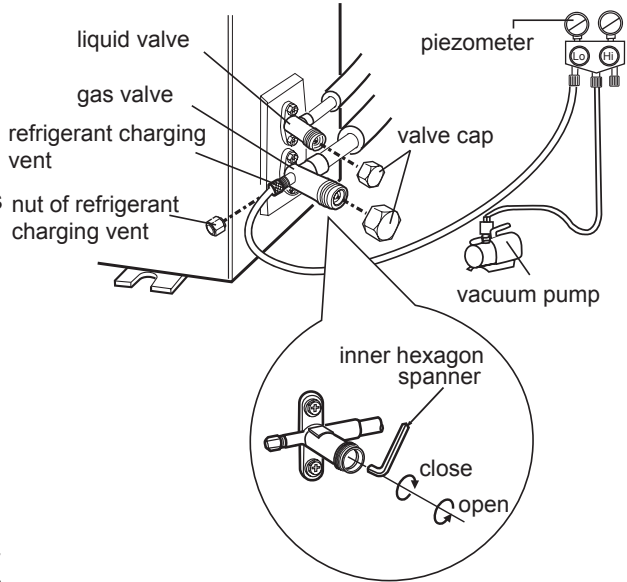

Fig.1

Vacuum pumping

Use vacuum pump

1. Remove the valve caps on the liquid valve and gas valve and the nut of refrigerant charging vent.
2. Connect the charging hose of piezometer to the refrigerant charging vent of gas valve and then connect the other charging hose to the vacuum pump.
3. Open the piezometer completely and operate for 10-15min to check if the pressure of piezometer remains in -0.1MPa .
4. Close the vacuum pump and maintain this status for 1-2min to check if the pressure of piezometer remains in -0.1MPa . If the pressure decreases, there may be leakage.
5. Remove the piezometer, open the valve core of liquid valve and gas valve completely with inner hexagon spanner.
6. Tighten the screw caps of valves and refrigerant charging vent.
7. Reinstall the handle.



Leakage detection

1. With leakage detector:
Check if there is leakage with leakage detector.
2. With soap water:
If leakage detector is not available, please use soap water for leakage detection. Apply soap water at the suspected position and keep the soap water for more than 3min. If there are air bubbles coming out of this position, there's a leakage.

Check after installation

- Check according to the following requirement after finishing installation.

Items to be checked	Possible malfunction
Has the unit been installed firmly?	The unit may drop, shake or emit noise.
Have you done the refrigerant leakage test?	It may cause insufficient cooling (heating) capacity.
Is heat insulation of pipeline sufficient?	It may cause condensation and water dripping.
Is water drained well?	It may cause condensation and water dripping.
Is the voltage of power supply according to the voltage marked on the nameplate?	It may cause malfunction or damaging the parts.
Is electric wiring and pipeline installed correctly?	It may cause malfunction or damaging the parts.
Is the unit grounded securely?	It may cause electric leakage.
Does the power cord follow the specification?	It may cause malfunction or damaging the parts.
Is there any obstruction in the air inlet and outlet?	It may cause insufficient cooling (heating) capacity.
The dust and sundries caused during installation are removed?	It may cause malfunction or damaging the parts.
The gas valve and liquid valve of connection pipe are open completely?	It may cause insufficient cooling (heating) capacity.

Test operation

1. Preparation of test operation

- The client approves the air conditioner.
- Specify the important notes for air conditioner to the client.

2. Method of test operation

- Put through the power, press ON/OFF button on the remote controller to start operation.
- Press MODE button to select AUTO, COOL, DRY, FAN and HEAT to check whether the operation is normal or not.
- If the ambient temperature is lower than 61°F(16°C), the air conditioner can't start cooling.

Configuration of connection pipe

1. Standard length of connection pipe
 - 16,5ft (5m), 25ft (7.5m), 26,5ft (8m).
2. Min. length of connection pipe is 10ft (3m).
3. Max. length of connection pipe and max. high difference.

Cooling capacity	Max length of connection pipe	Max height difference	Cooling capacity	Max length of connection pipe	Max height difference
5000Btu/h (1465W)	50ft (15)	16,5ft (5)	24000Btu/h (7032W)	83,3ft (25)	33,3ft (10)
7000Btu/h (2051W)	50ft (15)	16,5ft (5)	28000Btu/h (8204W)	100ft (30)	33,3ft (10)
9000Btu/h (2637W)	50ft (15)	16,5ft (5)	36000Btu/h (10548W)	100ft (30)	66,5ft (20)
12000Btu/h (3516W)	66,5ft (20)	33,3ft (10)	42000Btu/h (12306W)	100ft (30)	66,5ft (20)
18000Btu/h (5274W)	83,3ft (25)	33,3ft (10)	48000Btu/h (14064W)	100ft (30)	66,5ft (20)

4. The additional refrigerant oil and refrigerant charging required after prolonging connection pipe
 - After the length of connection pipe is prolonged for 33,3ft (10m) at the basis of standard length, you should add 5ml of refrigerant oil for each additional 5m of connection pipe.
 - The calculation method of additional refrigerant charging amount (on the basis of liquid pipe):

$$\text{Additional refrigerant charging amount} = \text{prolonged length of liquid pipe} \times \text{additional refrigerant charging amount per meter}$$
 - Basing on the length of standard pipe, add refrigerant according to the requirement as shown in the table. The additional refrigerant charging amount per meter is different according to the diameter of liquid pipe. See the following sheet.

Configuration of connection pipe

Additional refrigerant charging amount for R410A

Diameter of connection pipe		Outdoor unit throttle	
Liquid pipe(in)	Gas pipe(in)	Cooling only(g/m)	Cooling and heating(g/m)
Φ1/4	Φ3/8 or Φ1/2	15	20
Φ1/4 or Φ3/8	Φ5/8 or Φ3/4	15	50
Φ1/2	Φ3/4 or Φ7/8	30	120
Φ5/8	Φ1 or Φ1 1/4	60	120
Φ3/4	—	250	250
Φ7/8	—	350	350

Pipe expanding method

Note:

Improper pipe expanding is the main cause of refrigerant leakage. Please expand the pipe according to the following steps:

A: Cut the pipe

- Confirm the pipe length according to the distance of indoor unit and outdoor unit.
- Cut the required pipe with pipe cutter.

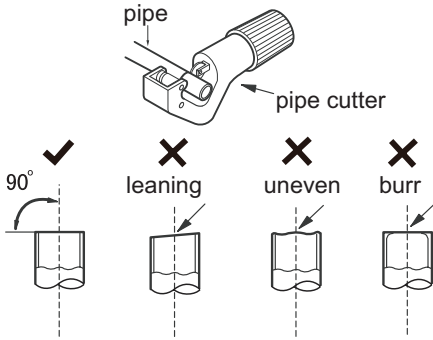

B: Remove the burrs

- Remove the burrs with shaper and prevent the burrs from getting into the pipe.

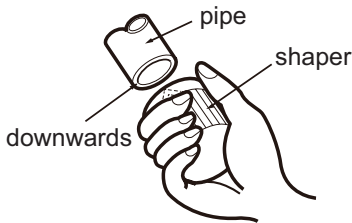

C: Put on suitable insulating pipe

D: Put on the union nut

- Remove the union nut on the indoor connection pipe and outdoor valve; install the union nut on the pipe.

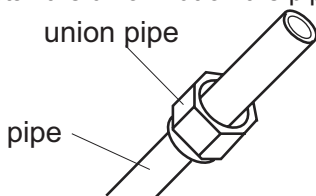

E: Expand the port

- Expand the port with expander.

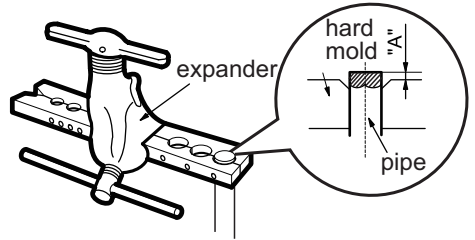

Note:

- "A" is different according to the diameter, please refer to the sheet below:

Outer diameter (in)	A(mm)	
	Max	Min
Φ1/4"	1.3	0.7
Φ3/8"	1.6	1.0
Φ1/2"	1.8	1.0
Φ5/8"	2.4	2.2

F: Inspection

- Check the quality of expanding port. If there is any blemish, expand the port again according to the steps above.

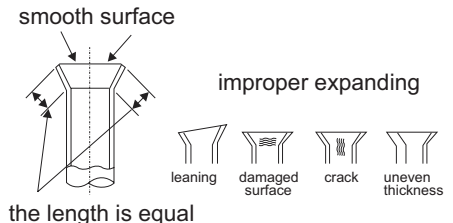

START-UP AND TROUBLESHOOTING

Explain Following Items To Customer With The Aid Of The Owner’s Manual:

1. How to turn system on and off; selecting COOLING, HEATING and other operating modes; setting a desired temperature; setting the timer to automatically start and stop system operation; and all other features of the Remote Control and display panel.
2. How to remove and clean the air filter.
3. How to set air with the swing louvers.
4. Explain care and maintenance.
5. Present the Owner’s Manual and installation instructions to customer.

Troubleshooting

This unit has onboard diagnostics. Error codes will appear on the LED display on the front panel of the indoor unit in place of the temperature display. The table below explains the error codes for both units.

DIAGNOSTIC CODES

Equipment Fault	Error Codes	Possible Causes
Indoor Configuration Jumper	C5	Missing Configuration Jumper on Indoor Control Board
Indoor/Outdoor Mismatch	LP	Indoor and Outdoor Units Do Not Match (Model or Capacity)
High Current Protection	E5	Power Supply is not Stable and Voltage Range is too Large
Communication Error	E6	Mis-wired or Communication Failure
Indoor Air Temp. Thermistor	F1	Bad Connection, or Indoor Air Sensor Failure
Indoor Coil Temp. Thermistor	F2	Bad Connection, or Indoor Coil Sensor Failure
Outdoor Air Temp. Thermistor	F3	Bad Connection, or Outdoor Ambient Sensor Failure
Outdoor Coil Temp. Thermistor	F4	Bad Connection, or Outdoor Coil Sensor Failure
Compressor Discharge Temp. Thermistor	F5	Bad Connection, or Discharge Sensor Failure
Compressor Overload Protection	H3	Low Refrigerant Charge, Blocked Capillary, or Compressor Motor Failure
IPM Module Protection	H5	IPM Module Temperature Too High, High Ambient, Low Voltage, or Bad Connections
Indoor Fan Malfunction	H6	Indoor Fan Stopped or Running too Slow
Compressor Synchronism	H7	High Pressure, Low Voltage, or Bad Connections
4-Way Valve Malfunction	U7	Bad Connection, Solenoid Failure, or Valve Malfunction. (Heat Pumps Only)
High Pressure Protection	E1	Too much refrigerant or High Ambient conditions or low airflow.

PRODUCT & INSTALLATION RECORD

For your convenience, please record the model and serial numbers of your new equipment in the spaces provided. This information, along with the installation data and dealer contact information, will be helpful should your system require maintenance or service.

UNIT INFORMATION

Model No. _____

Serial No. _____

INSTALLATION INFORMATION

Date Installed: _____

DEALERSHIP/INSTALLER INFORMATION

Company Name: _____

Address: _____

Phone Number: _____

Technician Name: _____

The design and specifications are subject to change without prior notice for product improvement. Consult with the sales agency or manufacturer for details.

